

INFLUENCE OF VEHICLE SIZE AND PERFORMANCE  
ON INTERSECTION SATURATION FLOW

Leonard Evans  
and

Richard W. Rothery  
Transportation and Traffic Science Department  
General Motors Research Laboratories  
Warren, Michigan 48090

ABSTRACT

This research was performed to investigate how vehicle size and performance affect the saturation flow of overloaded signalized intersections. Data were collected on 15 138 vehicles discharging from a signalized intersection when there were always more vehicles waiting to pass through than the green phase would permit. Saturation flow was examined as a function of vehicle length and headway. Vehicle size was also characterized by number of axles. The performance of the lead vehicle for each cycle was characterized by the time it took, after starting from a stop, to clear the intersection.

On the basis of the data analyzed, it is concluded that:

1. Smaller cars give higher intersection saturation flow.
2. When a queue leader is a low performance vehicle, saturation flow is reduced. One vehicle per cycle is lost for each additional two seconds the lead vehicle takes to clear the intersection.
3. Vehicles with low performance reduce saturation flow.
4. Large trucks are over-represented in queue leader positions.
5. Automatic traffic control schemes to minimize total system fuel use should strive to reduce likelihood of large trucks being queue leaders.

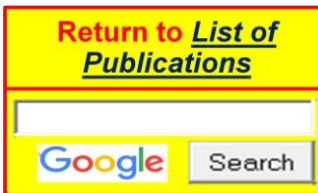

6. The fraction of large trucks in the sample observed to "run the red" was larger than the corresponding fraction for passenger cars.

#### INTRODUCTION

The efficient flow of traffic at signalized intersections has long been recognized as an important factor in yielding overall efficient traffic flow in urban areas. Many theoretical and experimental studies have been conducted on various aspects of this problem (see, for example, references in Pignataro [1]). In the present experimental investigation, detailed information on 15 138 vehicles discharging from a traffic signal was obtained using data collecting traps consisting of two tape switches placed on a roadway. The main aim was to study how vehicle size and performance influence intersection saturation flow.

A number of studies have addressed effects due to the size of passenger automobiles. Test track experiments [2] suggested that small cars yield higher intersection saturation flow than standard-sized cars. Observation of traffic at 12 signalized intersections in the metropolitan area of Toronto found higher saturation flow to be associated with small cars [3]. The magnitudes of the car-size effects in the above studies [2,3] are larger than would result solely from physical differences in car size, suggesting that the small cars are driven differently. Driver behavior studies support this contention. Reduced saturation flow resulted when the driver's view of the roadway was partially masked [4]. The amount of roadway visible to a driver following another vehicle influences his judgment of intervehicular spacing and may cause him to adopt different spacings when driving different cars even if he desires to maintain the same spacing [5]. This effect generally is in the direction of drivers of smaller cars following more closely, which would tend to increase intersection saturation flow for smaller cars. In the present study we seek additional

---

information on the effect of small cars; we also investigate lead vehicle acceleration and effects due to heavy vehicles. Some characteristics of vehicular platoons discharging when traffic signals turn green are also discussed.

To obtain traffic discharge as free as possible from extraneous variability, a site with the following characteristics was sought.

1. The intersection signal should remain oversaturated for a sufficient time to allow efficient data collection.
2. The roadway downstream from the signal should be sufficiently clear to allow relatively unimpeded discharges.
3. All turns should be prohibited. Even if exclusive turning lanes are provided, vehicles entering them when the queue is discharging can leave gaps in the through lanes which influence capacity.
4. As little interference as possible from cross-traffic should occur.

Many intersections were examined with respect to these criteria, but none found which satisfied all of them. As a compromise, the site described in the next section was selected.

#### DATA COLLECTION AND REDUCTION

A schematic of the site, which was in a suburban location 25 km North of the center of Detroit, is shown in Figure 1. The traffic signal, which had a 41 s green, 4 s yellow and 15 s red phase, controlled egress from a factory. Traffic in the two northbound lanes\* of the four lane roadway was studied. The speed limit was 45 miles per hour (72 km/h). The stop line in Fig. 1 indicates where vehicles

---

\*This stretch of roadway now has 6 lanes -- our data were collected in mid 1972.

typically stopped -- no stop line was marked on the roadway. The vehicles were measured 15 m beyond the stop line, a distance representative of that required to clear a typical intersection. This choice yields information on, for example, the effects of vehicular acceleration that is not available at a position a meter or so beyond the stop line, a position chosen for headway measurements in a number of earlier studies [3, 6, 7].

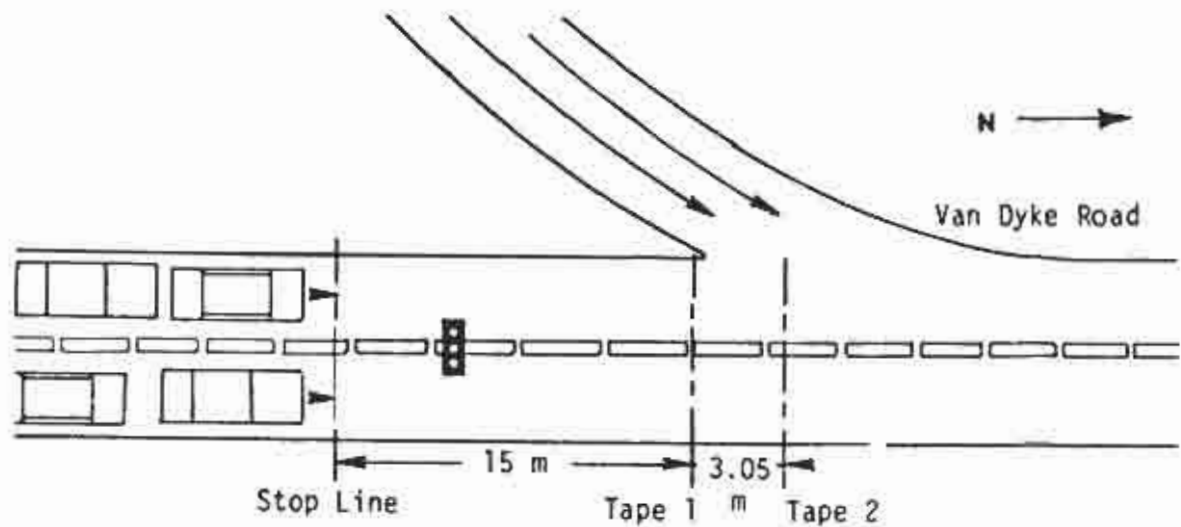

Figure 1. The site.

Data were collected in each lane using a "trap" consisting of a pair of tape switches. These are conducting strips separated by a compressible insulator. A vehicle crossing the tape closes the switch. Each vehicle (or, more generally, each pair of axles) yields four time events when it crosses the two tape switches in its lane. These were synchronously recorded using a multiple channel tape recorder. From these four recorded times the speed, acceleration and wheelbase of the vehicle can be estimated (for a similar approach, see ref. 8).

Calculation of Wheelbase, Speed and Acceleration

Consider a vehicle, wheelbase  $W$ , crossing a "trap" of length  $D$ , as shown in Fig. 2. Let the front wheels strike the first and second tapes at times  $t_1$  and  $t_2$  respectively; let the rear wheel strike the first and second tapes at  $t_3$  and  $t_4$  respectively.

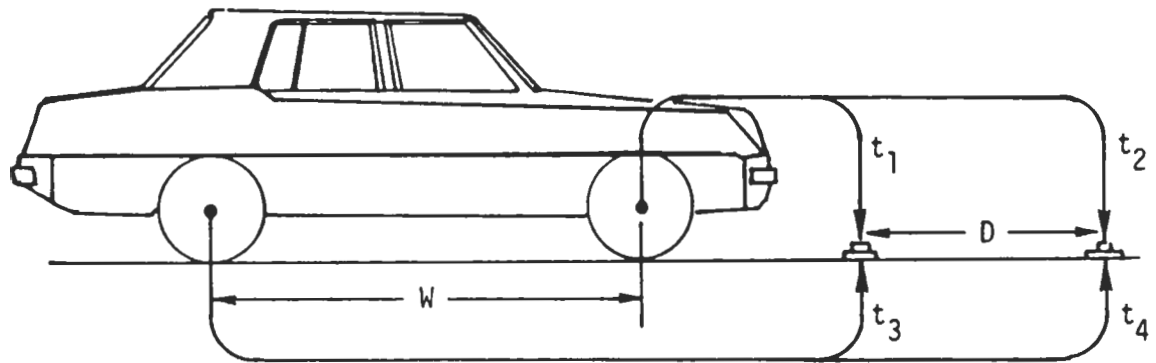

Figure 2. Definition of the four time events.

Let the position of the front axle of the vehicle be given by

$$x = f(t) \tag{1}$$

Then, the rear axle position is given by

$$x_R = f(t) - W$$

A space-time diagram with arbitrarily positioned tape switches is shown in Fig. 3. If the coordinates are transformed so that the position origin is at the first tape and the origin of time is when the first axle crosses the first tape switch, then, with upper case letters denoting the transformed coordinates, we obtain

$$T_1 = t_1 - t_1 = 0,$$

$$T_2 = t_2 - t_1, \text{ etc.}$$

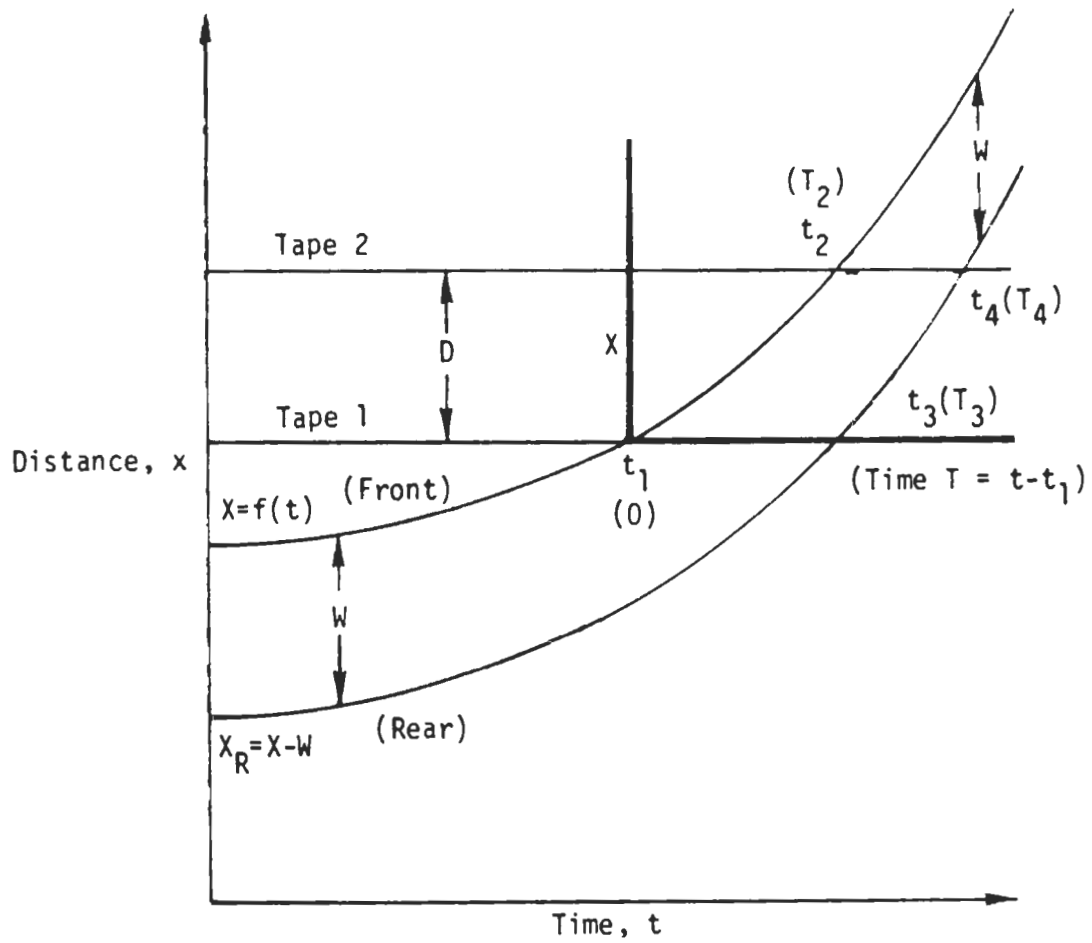

Figure 3. Speed-time history of vehicle traversing two-tape trap.

Let us represent the trajectory of the vehicle by a polynomial in  $T$ , and ignore third and higher order terms in  $T$ . That is, the highest order effect within the trap is assumed to be a uniform acceleration. Then, because  $X = 0$  at  $T = 0$ , we can write

$$X = X(T) = bT + cT^2 \tag{5}$$

Substituting the time and distance values for the other three events into Equation 5 yields

$$D = bT_2 + cT_2^2 \tag{6}$$

$$W = bT_3 + cT_3^2 \quad \text{and} \quad (7)$$

$$D + W = bT_4 + cT_4^2$$

Solving these equations for  $b$ ,  $c$ , and  $W$  gives:

- The speed of the vehicle,  $v$ , on entering the trap (that is,  $b$  from equation (5)) is

$$v = D \frac{T_2 + T_3 - T_4}{T_2(T_4 - T_3)(T_3 + T_4 - T_2)}$$

- The average acceleration,  $a$  ( $2c$  from equation (5)), is

$$a = 2D \frac{T_2 + T_3 - T_4}{T_2(T_4 - T_3)(T_3 + T_4 - T_2)} \quad (10)$$

- The wheelbase,  $W$ , is

$$W = \frac{DT_3}{T_2} \frac{(T_4 - T_2)(T_2 + T_4 - T_3)}{(T_4 - T_3)(T_3 + T_4 - T_2)} \quad (11)$$

Note that if the front wheels strike the second tape at the same time as the rear wheels strike the first tape (i.e.,  $T_2 = T_3$ ), one always correctly infers from equation (11) that  $W = D$  even if  $f(T)$ , contrary to our simplifying assumption, contains third or higher order terms. This would argue in favor of choosing a value of  $D$  close to typical values of  $W$ .

The value  $D = 3.05$  m was used for the trap length throughout the experiment.

Procedure

In order to check equipment and procedures, traps were laid on two lanes of a non-public road and a subcompact car was driven 18 times through the right lane trap and 17 times through the left lane trap at various speeds and accelerations. The standard deviations of the wheelbase measurements were 6 mm for the right lane and 7 mm for the left lane. This precision, better than 0.3%, indicates high potential of this technique for vehicle identification.

The traps were laid at the observation site just prior to the p.m. peak period. A major problem with tape switches is reliability. After many passages of very heavy vehicles, tape switches are liable to permanently close, and many such failures were encountered. If the trap in one lane became inoperative, data collection continued in the other. Usable data were obtained for 6 afternoon (about 3:45 p.m. to 5:15 p.m.) peak periods.

The authors observed the discharging traffic from a car parked on the soft shoulder near the stopping line. This car also contained the instrumentation. It was necessary to note all vehicles with more than two axles (we will refer to such vehicles as many-axle vehicles) because the instrumentation cannot discriminate between, say, certain vehicles with four axles and two closely following vehicles with two axles each. Untypical vehicles (motorcycle, car hauling boat, etc.) and easily recognizable vehicle makes and models were also noted.

Data Set

The analysis was performed using a data set containing the following information for each of 15 138 vehicles (see Table 1):

right or left lane used  
 number of axles  
 particular model or type of vehicle if available  
 from notes

---



queue position  
 arrival time  
 time front axle reaches first tape switch after  
 the onset of the green phase  
 clearing time  
 time last axle reaches first tape switch after the  
 onset of green phase  
 speed on entering the trap  
 acceleration  
 total wheelbase

TABLE 1. DATA SUMMARY

|   | RIGHT<br>LANE | LEFT<br>LANE |
|---|---------------|--------------|
| NUMBER OF TRAFFIC<br>SIGNAL CYCLES<br>(=NUMBER OF QUEUE<br>LEADERS) | 408           | 981          |
| NUMBER OF VEHICLES<br>NOT QUEUE LEADERS                             | 7230          | 7119         |
| TOTAL NUMBER<br>OF VEHICLES   | 7638          | 7500         |
| NUMBER OF VEHICLES<br>WITH THREE OR<br>MORE AXLES                   | 229           | 12           |

In addition, the following two quantities were calculated for each vehicle that was not a queue leader:

Headway - defined here as the time between the rear axle of the previous vehicle crossing the first tape and the rear axle of the vehicle in question crossing the first tape. This headway corresponds approximately to how much green time the vehicle consumes.

Gap - defined here as the time between the rear axle of the previous vehicle crossing the first tape and the front axle of the vehicle in question crossing the first tape. Apart from the question of how far vehicles extend beyond their front and rear axles, and the fact that the vehicles were not measured simultaneously, this gap is determined by the chosen following distance and speed of each driver.

## RESULTS

Effect of Vehicle Size on Gaps and Headways

In order to study effects associated with vehicle size, the vehicles were divided into seven wheelbase categories as shown in Table 2. The boundaries of these wheelbase categories were chosen to delineate, as far as possible, different body classifications. These wheelbase intervals generally contained a local maximum from the wheelbase distribution. For both lanes, the mode of the wheelbase distribution was at 3.07 m (121 inches). The representative vehicle given in Table 2 for each category is a typical

TABLE 2. GAPS AND HEADWAYS (SECONDS) FOR VEHICLES WITH DIFFERENT SIZE WHEELBASES

| SIZE CAT-EGORY    | TYPICAL VEHICLE TYPE | WHEELBASE RANGE, METERS | RIGHT LANE |                |                |      | LEFT LANE |                |                |      |
|-------------------|----------------------|-------------------------|------------|----------------|----------------|------|-----------|----------------|----------------|------|
|                   |                      |                         | N          | GAP S.D.       | HEADWAY S.D.   | pce  | N         | GAP S.D.       | HEADWAY S.D.   | pce  |
| 1                 | MOTORCYCLE, ETC.     | <2.35                   | 123        | 1.75<br>(1.02) | 1.92<br>(1.04) | 0.96 | 95        | 1.61<br>(0.90) | 1.76<br>(0.91) | 0.88 |
| 2                 | SUBCOMPACT CAR       | 2.35 to 2.58            | 635        | 1.68<br>(0.73) | 1.90<br>(0.72) | 0.95 | 729       | 1.75<br>(0.90) | 1.94<br>(0.89) | 0.97 |
| 3                 | COMPACT CAR          | 2.58 to 2.86            | 1632       | 1.73<br>(0.68) | 1.98<br>(0.68) | 0.99 | 1540      | 1.79<br>(1.04) | 2.00<br>(1.04) | 1.00 |
| 4                 | INTERMEDIATE CAR     | 2.86 to 3.01            | 1424       | 1.77<br>(0.77) | 2.03<br>(0.77) | 1.01 | 1388      | 1.86<br>(1.34) | 2.09<br>(1.33) | 1.04 |
| 5                 | LARGE CAR            | 3.01 to 3.21            | 2517       | 1.77<br>(0.81) | 2.05<br>(0.80) | 1.02 | 2700      | 1.78<br>(0.93) | 2.01<br>(0.92) | 1.00 |
| 6                 | LIGHT TRUCK, VAN     | 3.21 to 3.81            | 609        | 1.93<br>(0.88) | 2.22<br>(0.88) | 1.10 | 633       | 1.85<br>(0.98) | 2.10<br>(0.98) | 1.04 |
| 7                 | HEAVY TRUCK, ETC.    | >3.81                   | 290        | 3.65<br>(1.92) | 4.69<br>(2.18) | 3.33 | 34        | 3.17<br>(2.50) | 3.68<br>(2.63) | 1.83 |
| ENTIRE POPULATION |                      |                         | 7230       | 1.84<br>(0.93) | 2.13<br>(1.02) | 1.06 | 7119      | 1.81<br>(1.06) | 2.03<br>(1.06) | 1.01 |

member of that category. However, each category contains a variety of vehicle types. For example, category 6 contained some very large cars.

Vehicles in categories 2 through 5 are predominantly passenger cars, including station wagons. For these, clear cut systematic average gap size differences dependent on vehicle size are not apparent from the data in Table 2. Nonetheless, the average gap for category 2 vehicles is less than that for category 4 and category 5 vehicles in both right and left lanes. Indeed, a two-tailed t-test applied to individual pairs of differences without regard to the others yields the following statistically significant differences:

Right lane: average category 2 gap < average category 4 gap ( $p < 0.02$ );  
 average category 2 gap < average category 5 gap ( $p < 0.02$ ).

Left lane: average category 2 gap < average category 4 gap ( $p < 0.05$ ).

As the average speed of vehicles entering the trap was 45 km/h, a gap difference of 0.1 s corresponds typically to 1.2 m, suggesting that category 2 drivers chose spacings between their front axle and the vehicle they were following about a meter less than the corresponding spacing for category 4 and 5 drivers. Some portion of this difference is attributable to the trend of increasing front-axle to front-bumper dimension for cars of larger size. Therefore, the present data offer at most a suggestion that drivers of smaller size vehicles adopt smaller intervehicular spacings.

The green time consumed by a vehicle is, approximately, what we have defined as headway; namely, gap plus the time taken for the vehicle to travel the distance of its own wheelbase. The data in Table 2 show that headway increases with vehicle size so that flow, which is the reciprocal of headway, decreases with vehicle size. For example, the

---

right lane flow during the discharge for category 2 vehicles (1895 veh/h) is 7.9% greater than that for category 5 vehicles (1756 veh/h); the corresponding left lane difference is 3.6%. Because of a general increase in rear-axle to rear-bumper distance with increasing car size, these differences are less than would be calculated by using the more appropriate time the vehicle takes to travel a distance equal to its length rather than its wheelbase.

Vehicles in categories 6 and 7 had larger gaps than those in the other categories. This probably arises because, with lower power to weight ratios, they were on balance unable to match the acceleration of vehicles they were following.

The average headways of these larger vehicles are now compared to the average headway of all the vehicles in categories 2 through 5 (i.e. 2.01 s) which we take as the average passenger car headway. For both lanes combined, category 6 and 7 vehicles had average headways 2.16 s and 4.58 s, respectively. Thus, for non-queue leader positions, a category 6 vehicle corresponds to  $2.16/2.01 = 1.07$  passenger car equivalents (pce) (for a more detailed discussion of pce, see, e.g., p. 353 of Reference 1). The corresponding value for a category 7 vehicle is  $4.58/2.01 = 2.28$  pce.

All the many-axle vehicles in our sample were category 7. Indeed, almost all category 7 vehicles were many-axle. It has been indicated elsewhere that the number of axles is a good parameter to characterize the weight of heavy trucks, both when loaded and unloaded [9]. In the present paper we examine a number of effects of vehicles discharging from a traffic signal in terms of number of axles.

Average headway and pce inferred from headway, together with other quantities to be discussed later, are given in Table 4 as a function of the number of axles of many-axle vehicles (also see Figure 4). It is apparent that headway generally increases with the number of axles; the average

---

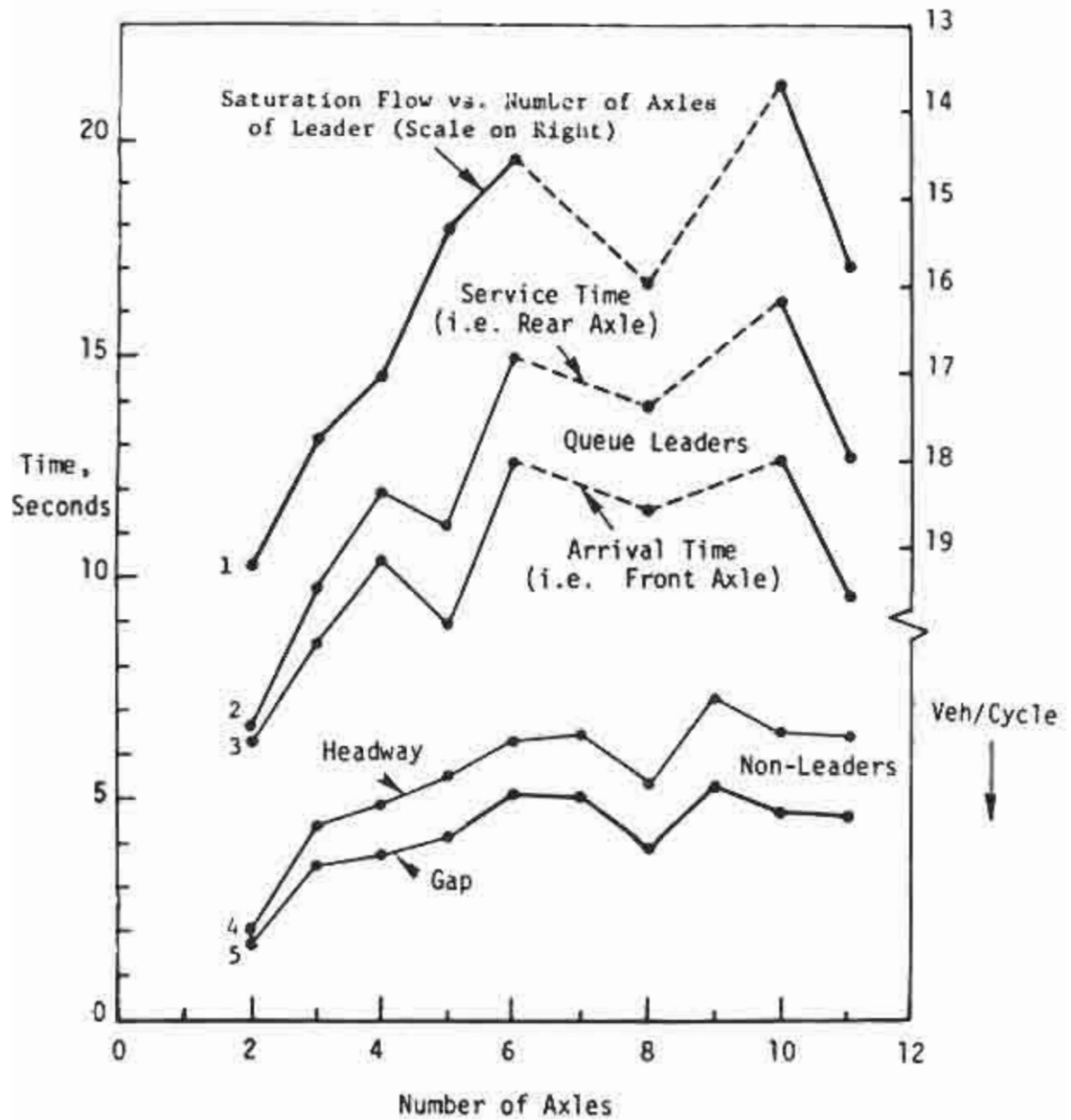

Figure 4. From top to bottom

1. Saturation flow versus number of axles of queue leader.
- 2 (and 3). Queue leader service time (arrival time) (i.e., time required after onset of green for last (first) axle to reach tape 1) versus number of axles.
- 4 (and 5). Headway (gap) averaged over all non-leader queue positions for vehicles with different numbers of axles.

headway of many-axle vehicles in a non-queue leader position correspond to 2.63 pce.

#### Effect of Queue Leaders on Throughput

The average saturation flow (i.e., vehicles per cycle with 45 s green plus yellow) that occurred when vehicles in the different size categories were queue leaders is shown in Table 3. No systematic effects due to size category of leaders are apparent when the leader is a member of categories 2 through 5 (i.e., a passenger car). The average throughput associated with passenger car leaders is 19.05 veh/cycle for the right lane and 19.71 veh/cycle for the left lane. When a category 6 vehicle rather than a passenger car is a leader, throughput is reduced by 0.63 veh/cycle in the right lane and 0.34 veh/cycle in the left lane. To express these throughput reductions in terms of pce we note that (see Table 2) an average non-queue leader vehicle in the right lane is equivalent to  $2.13/2.01 = 1.06$  pce. The corresponding number for the left lane is  $2.03/2.01 = 1.01$  pce. Using these values, we infer that, as

TABLE 3. SATURATION FLOW FOR DIFFERENT SIZE QUEUE LEADERS

| SIZE CAT-EGORY    | TYPICAL VEHICLE TYPE | WHEELBASE RANGE, METERS | RIGHT LANE    |                         |                         | LEFT LANE     |                         |                         |
|-------------------|----------------------|-------------------------|---------------|-------------------------|-------------------------|---------------|-------------------------|-------------------------|
|                   |                      |                         | NO. OF CYCLES | AVERAGE ARRIVAL TIME, s | AVG. CAPACITY VEH/CYCLE | NO. OF CYCLES | AVERAGE ARRIVAL TIME, s | AVG. CAPACITY VEH/CYCLE |
| 1                 | MOTORCYCLES, ETC.    | <2.35                   | 7             | 6.96                    | 18.57                   | 4             | 6.94                    | 20.50                   |
| 2                 | SUBCOMPACT CAR       | 2.35 to 2.58            | 33            | 6.31                    | 19.30                   | 32            | 5.94                    | 19.25                   |
| 3                 | COMPACT CAR          | 2.58 to 2.86            | 79            | 6.35                    | 18.70                   | 85            | 6.01                    | 19.60                   |
| 4                 | INTERMEDIATE CAR     | 2.86 to 3.01            | 80            | 6.29                    | 19.09                   | 73            | 5.98                    | 20.01                   |
| 5                 | LARGE CAR            | 3.01 to 3.21            | 146           | 6.28                    | 19.15                   | 152           | 5.91                    | 19.72                   |
| 6                 | LIGHT TRUCK, VAN     | 3.21 to 3.81            | 36            | 6.60                    | 18.42                   | 35            | 6.07                    | 19.37                   |
| 7                 | HEAVY TRUCK, ETC.    | >3.81                   | 27            | 9.61                    | 16.67                   | 0             | --                      | --                      |
| ENTIRE POPULATION |                      |                         | 408           | 6.56                    | 18.72                   | 381           | 5.97                    | 19.68                   |

far as the directly measured effect on capacity is concerned, a category 6 vehicle queue leader is equivalent to 1.67 pce in the right lane and 1.34 pce in the left lane. The difference between the lanes might suggest that drivers of category 6 vehicles with comparatively higher acceleration capabilities were choosing the left lane. The values for both lanes are larger than the previously mentioned value of 1.07 pce of a category 6 vehicle that was not a queue leader.

There were no category 7 queue leaders in the left lane data. The capacity when a category 7 vehicle was queue leader in the right lane is 2.38 veh/cycle less (i.e., 19.05 - 16.67 from data in Table 3) than when a passenger car was leader. A category 7 queue leader is hence equivalent to  $1 + 2.38 \times 1.06 = 3.52$  pce when it is a queue leader as compared to previously noted value of 2.28 pce when it is not a queue leader. Thus the capacity penalty for a category 7 vehicle is more than 1 pce greater when it is a queue leader than when it is a non-queue leader.

More detailed information on this effect is given in Table 4, which shows pce equivalents of vehicles with given numbers of axles in lead and non-lead positions.

Intersection capacity is now analyzed in terms of the arrival time (that is, the time after onset of green to travel 15 m) of the lead vehicle. This time is related to the average acceleration initially used to clear the intersection -- longer times being associated with lower acceleration. Average capacity versus the arrival time of the lead vehicle (in 0.4 s cells) is shown in Figure 5 for both lanes combined. Only points that are averages of three or more observations are plotted; a few individual cycles showed erratic departures from the trend in Figure 5. The line is an unweighted least squares fit to the points plotted. The reciprocal of the slope of this line indicates that the capacity is reduced by one veh/cycle for each additional 1.92 s delay that the lead vehicle takes to reach

the clearing line. This is consistent with the usual interpretation (see, e.g., p. 351 of Reference 1) that a lead car delay consumes effective green time that would otherwise be available to serve vehicles at the previously determined rate of one passenger car per 2.01 s. Note that the arrival time that corresponds to zero capacity for the regression equation given in Figure 5 is 43.4 s, a value close to the actual effective green time of 45 s for the particular signal being studied.

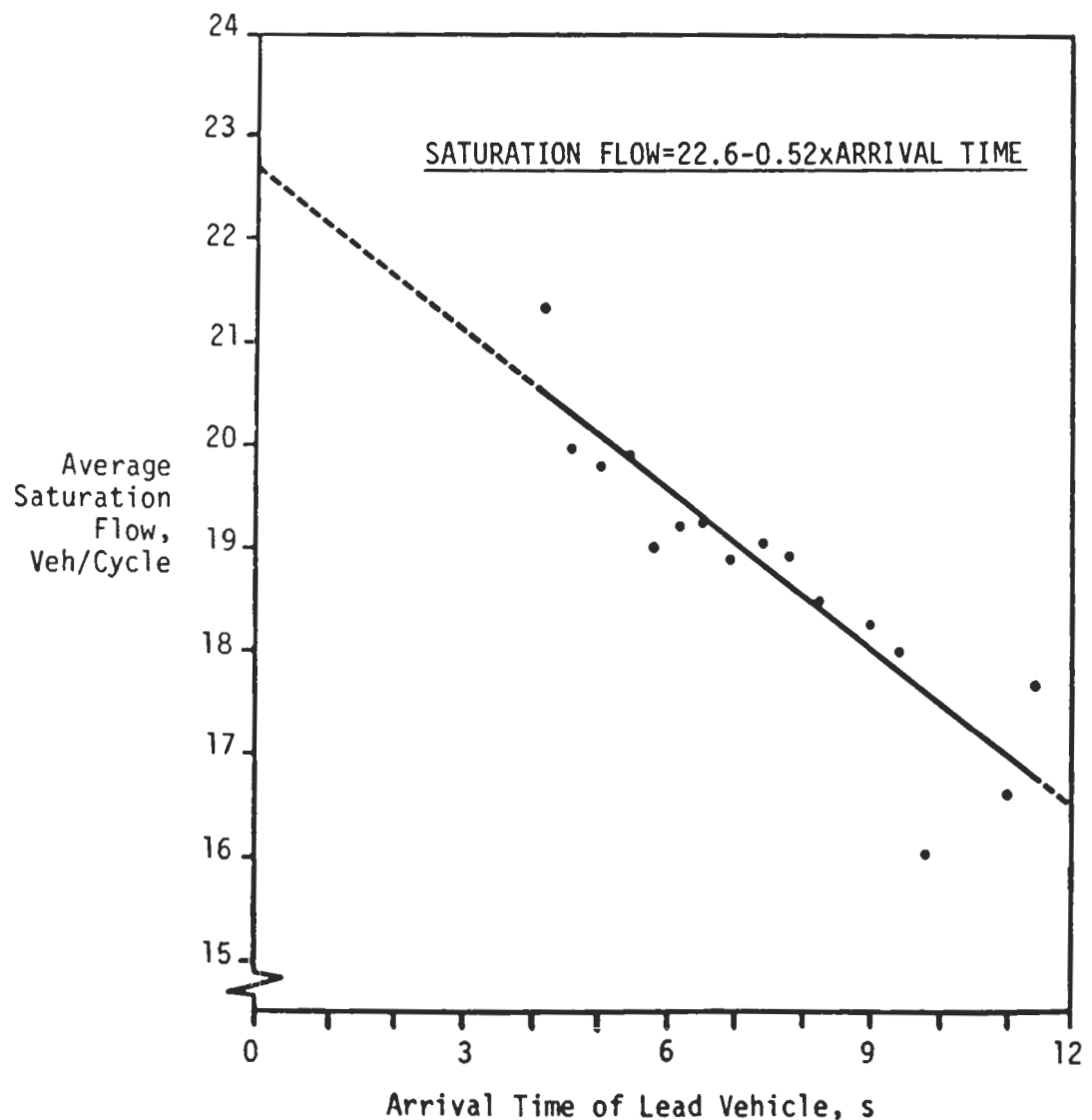

Figure 5. Saturation flow versus arrival time of lead vehicle. The data are grouped in 0.4 second cells. Only cells with three or more data are plotted. The line is an unweighted least squares fit to the points plotted.



Arrival times for different size queue leaders are shown in Table 3. For passenger car queue leaders (categories 2 through 5), there are no effects dependent on car size. However, arrival times are systematically longer for the right lane than the left lane for all size categories, suggesting that faster accelerating drivers choose the left lane.

Equations expressing average instantaneous acceleration of different classes of lead vehicles in terms of time since starting to move are given by Dockerty [10]. Our arrival times (i.e. 6.30 s for passenger cars and 9.61 s for category 7 vehicles), after subtracting 1.5 s to represent a delay between onset of green and the vehicle's starting to move, were substituted into Dockerty's (10) Equation 4 (for cars) and Equation 5 (for "heavies"), to yield the following acceleration estimates:  $1.01 \text{ m/s}^2$  for cars and  $0.29 \text{ m/s}^2$  for heavies. These may be compared to our directly measured average values of acceleration at the trap for cars and category 7 vehicles, which were  $1.38 \text{ m/s}^2$  and  $0.39 \text{ m/s}^2$ , respectively. The essentially instantaneous value of acceleration measured at the trap does not provide a reliable indication of average acceleration since starting for individual vehicles, especially large vehicles. For example, a gear change by an "accelerating" vehicle while traversing the trap can even lead to a negative acceleration measurement within the trap. However, this effect does not invalidate the comparison of averages given above. A better indicator of individual vehicle performance is arrival time, which is the variable used in Figure 5.

Another approach to determining saturation flow reduction due to lead vehicles is to examine clearing times of different queue leaders. We confine this discussion to the 22 vehicles in the right lane that had more than two axles (all are category 7). The data are shown in Table 4 and plotted in Figure 4. By subtracting the average clearing

time for a passenger car queue leader in the right lane (namely, 6.60 s) from these and dividing by 2.01 s the losses in saturation flow shown in Table 4 were determined. The pce of a leader derived from the clearing time is compared to that derived from the directly measured reduction in saturation flow. The two values are in relatively good agreement, and the average is taken as the best estimate of the saturation flow reduction associated with a lead vehicle with a given number of axles. This average value is compared in Table 4 with the pce of vehicles with the same number of axles that were not queue leaders. It can be seen that an additional capacity reduction of 1.42 pce is associated with a many-axle vehicle being a queue leader as compared to its not being a queue leader. This penalty is compounded by the fact that the probability of a random many-axle vehicle in the traffic stream becoming a queue leader is greater than the fraction of many-axle vehicles in the traffic stream, as shown below.

TABLE 4. SATURATION FLOW REDUCTIONS FOR MANY-AXLE VEHICLES IN QUEUE LEADER AND NON-QUEUE LEADER POSITIONS

| NO. OF AXLES | QUEUE LEADERS |                          |                 |                  |                        |                              | NON-QUEUE LEADERS |                   |                  | ADDNL. PENALTY WHEN A QUEUE LEADER (pce) |
|--------------|---------------|--------------------------|-----------------|------------------|------------------------|------------------------------|-------------------|-------------------|------------------|--|
|              | N             | DIRECTLY OBSERVED VEH/CY | pce FROM VEH/CY | CLEARING TIME, s | pce FROM CLEARING TIME | AVERAGE pce FOR QUEUE-LEADER | N                 | AVERAGE HEADWAY s | pce FROM HEADWAY |  |
| 3            | 6             | 17.67*                   | 2.46            | 9.79*            | 2.58                   | 2.52                         | 65                | 4.47*             | 2.22             | 0.30                                     |
| 4            | 3             | 17.00                    | 3.17            | 12.07            | 3.72                   | 3.44                         | 57                | 4.95              | 2.46             | 0.98                                     |
| 5            | 3             | 15.33                    | 4.94            | 11.18            | 3.28                   | 4.11                         | 28                | 5.56              | 2.76             | 1.35                                     |
| 6            | 2             | 14.50                    | 5.82            | 14.95            | 5.15                   | 5.49                         | 10                | 6.42              | 3.19             | 2.30                                     |
| 7            | 0             | ---                      | ---             | ---              | ---                    | ---                          | 7                 | 6.58              | 3.27             | ---                                      |
| 8            | 1             | 16.00                    | 4.23            | 13.79            | 4.58                   | 4.40                         | 5                 | 5.37              | 2.67             | 1.73                                     |
| 9            | 0             | ---                      | ---             | ---              | ---                    | ---                          | 3                 | 7.30              | 3.63             | ---                                      |
| 10           | 3             | 13.67                    | 6.70            | 16.31            | 5.83                   | 6.27                         | 5                 | 6.59              | 3.28             | 2.99                                     |
| 11           | 4             | 15.75                    | 4.49            | 12.71            | 4.04                   | 4.26                         | 27                | 6.47              | 3.22             | 1.04                                     |
| ALL          | 22            | 16.0                     | 4.23            | 12.36            | 3.87                   | 4.05                         | 207               | 5.29              | 2.63             | 1.42                                     |

\*THE CORRESPONDING VALUES FOR PASSENGER CARS ARE 19.05 VEH/CYCLE, 6.60 s AND 2.01 s, RESPECTIVELY.

### Does Probability of Being Queue Leader or Last Vehicle Depend on Vehicle Size?

Here we address the question: do all types of vehicles have an equal likelihood of becoming queue leaders or last vehicles? If so, then the number of queue leaders of a

certain type of vehicle would be proportional to the number of such vehicles in the traffic stream. To address this question passenger cars (i.e. categories 2 - 5) are compared to many-axle vehicles (see Table 5). Because category 1 and 6 vehicles and category 7 vehicles with 2 axles are not included in Table 5, the two columns do not sum to the total sample values in Table 1.

TABLE 5. PROBABILITY OF RANDOM PASSENGER CARS AND RANDOM MANY AXLE VEHICLES IN TRAFFIC STREAM BEING IN FIRST AND LAST POSITION IN RIGHT LANE.

|  | PASSENGER CARS<br>(CATEGORIES 2 THROUGH 5) | VEHICLES WITH THREE<br>OR MORE AXLES |
|--|--|--------------------------------------|
| TOTAL NUMBER OF VEHICLES                   | 6546                                       | 229                                  |
| NUMBER OF QUEUE LEADERS                    | 338  | 22                                   |
| PERCENT OF VEHICLES THAT WERE QUEUE LEADER | 5.16%                                      | 9.61%                                |
| NUMBER OF LAST VEHICLES                    | 339  | 23                                   |
| PERCENT OF VEHICLES THAT WERE LAST VEHICLE | 5.18%                                      | 10.04%                               |
| AVERAGE HEADWAY (OF NON-QUEUE LEADERS)     | 2.01 s                                     | 5.29 s                               |
| AVERAGE GAP (OF NON-QUEUE LEADERS)         | 1.75 s                                     | 4.02 s                               |

Of the total of 6546 passenger cars in the right lane, 338 were queue leaders and 339 were last vehicles, corresponding to 5.16% and 5.18% respectively. That is, a passenger car in the traffic stream had a 5.2% possibility of becoming a queue leader or a last vehicle. Of 229 many-axle vehicles, 22 were queue leaders and 23 were last vehicles. That is, the probability of a many-axle vehicle in the traffic stream becoming a queue leader was 9.16%, and of becoming a last vehicle was 10.04%. Applying a chi-squared test to 2 x 2 contingency tables shows that both these proportions differ from the passenger car proportion at  $p < 0.01$ .

These probabilities imply that a random many-axle vehicle in the traffic stream is  $9.16/5.16 = 1.86$  times as likely to become a queue leader and  $10.04/5.18 = 1.94$  times as likely to become a last vehicle as is a random passenger car.

The probability that a vehicle is stopped by the onset of red to become queue leader of the next cycle should be, other factors being equal, proportional to its headway\*. The headway of a many-axle vehicle is 2.63 times (see Table 4) that of a passenger car, considerably more than the 1.86 ratio in which many-axle vehicles were over-represented as queue leaders.

A simple model of the discharge process suggests that the probability of a particular vehicle becoming a last vehicle should not depend on its headway. Hence some additional factor is needed to explain the over-representation of many-axle vehicles in the last position and the fact that their over-representation in the lead position is less than proportional to that indicated by their headways.

The average arrival and clearing times of last vehicles in various categories, including number of axles for many-axle vehicles, is shown in Table 6. Fourteen last vehicles, all two-axle, judged at time of data collection to be not followed by another vehicle, are excluded from the data in Table 6. The average arrival time for many-axle vehicles is 0.80 s later than that for passenger cars. A t-test shows this difference to be significant at  $p < 0.05$ . Hence, many-axle vehicles showed a greater tendency to enter the intersection after the onset of the red phase.

The clearing times which include the effect due to vehicle length increase with number of axles (see Table 6 and Figure 6). Average clearing time for many-axle vehicles

---

\*Assumes goal is that entire vehicle clears intersection by onset of red. The discussion is similar if gap rather than headway is used, the resulting ratio, 2.30, being somewhat closer to 1.86.

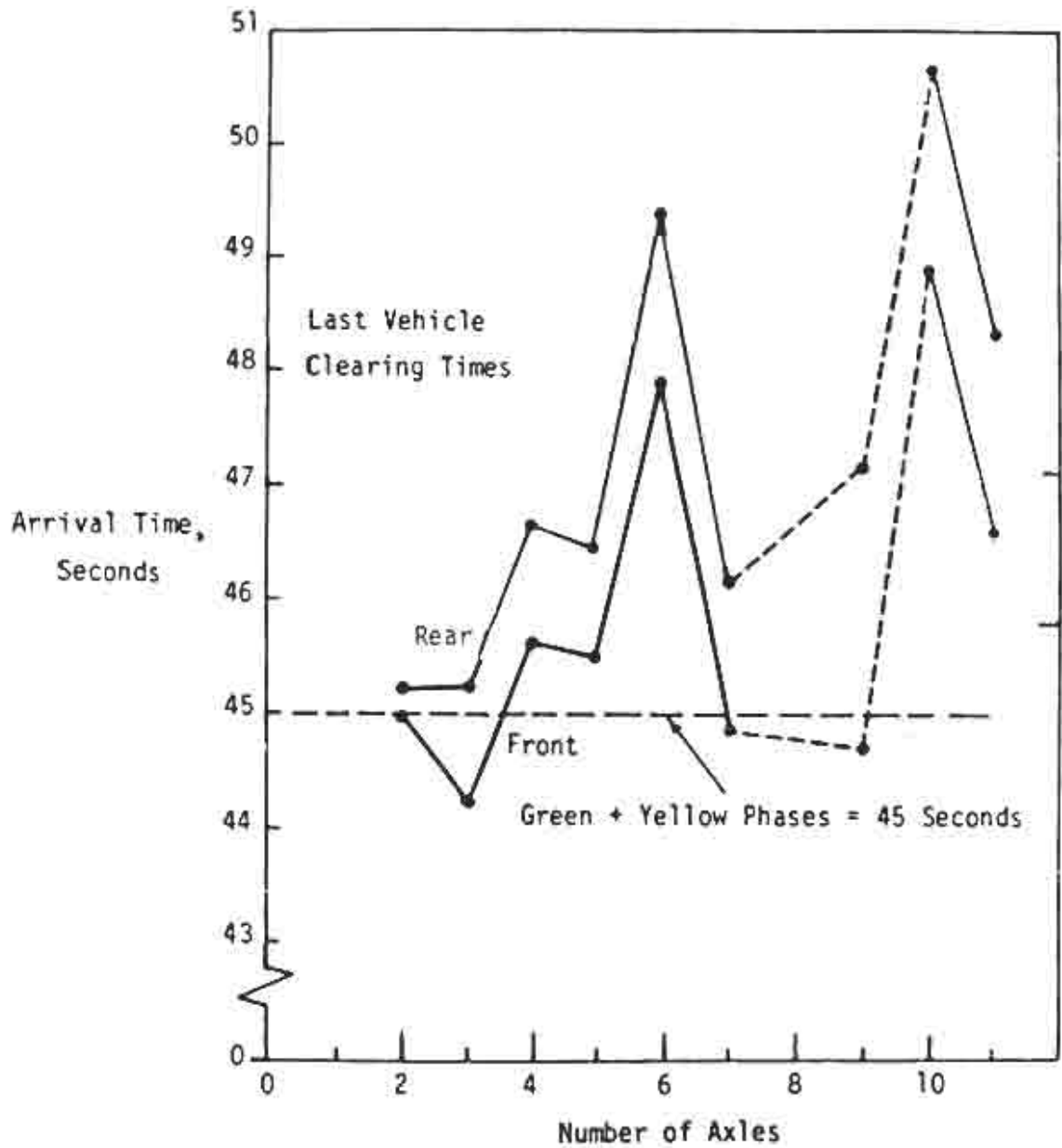

Figure 6. Average clearing (arrival) times (i.e., time required after onset of green for last (first) axle to reach tape 1) for last vehicle in cycle versus number of axles of last vehicle. Points above the dotted line indicate presence in intersection after the onset of the red phase.

was 47.11 s, which is 1.88 s more than the average for passenger cars. Note that if this is subtracted from the average headway for many-axle vehicles given in Table 5, the ratio of the headways of many-axle vehicles to passenger cars becomes  $3.41/2.01 = 1.70$ , a value in much closer agreement with the ratio, namely 1.86, in which many-axle vehicles were over-represented as queue leaders.

Any arrival of a rear axle at a time greater than 45 s may reduce cross-traffic capacity. It is possible that the untypical nature of the signal studied, involving no normal cross-traffic, was conducive to a greater tendency to be in the intersection at the onset of red than would occur at a more typical intersection. A factor that could contribute to the many-axle vehicles' greater probability in this regard is the increase in the size of the so-called "dilemma zone" [11] as vehicle length increases. The average total wheel-base of the many-axle vehicles is 11.6 m, about 8.7 m greater than for a typical car.

There are not statistically significant differences between the arrival times or clearing times of last vehicles that depend on car size for vehicles in categories 2 through 5. This absence of any car-size effects on the probability of being a violator is in agreement with an earlier finding of Evans and Rothery [12].

TABLE 6. ARRIVAL TIMES AND CLEARING TIMES OF LAST VEHICLES (SECONDS SINCE BEGINNING OF GREEN PHASE) FOR RIGHT LANE

| VEHICLE SAMPLE         | SAMPLE SIZE | AVERAGE ARRIVAL TIME (FIRST AXLE AT TAPE 1) | AVERAGE CLEARING TIME (LAST AXLE AT TAPE 1) |
|------------------------|-------------|---|---|
| CATEGORY 1*            | 10          | 44.21                                       | 44.34                                       |
| 2                      | 36          | 44.87                                       | 45.06                                       |
| 3                      | 93          | 45.04                                       | 45.25                                       |
| 4                      | 68          | 45.09                                       | 45.32                                       |
| 5                      | 129         | 44.98                                       | 45.22                                       |
| 6                      | 31          | 45.32                                       | 45.58                                       |
| 7                      | 27          | 45.80                                       | 46.60                                       |
| PASSENGER CARS (**)    | 326         | 45.01                                       | 45.23                                       |
| 3 AXLE                 | 3           | 44.26                                       | 45.24                                       |
| 4                      | 8           | 45.65                                       | 46.69                                       |
| 5                      | 2           | 45.56                                       | 46.46                                       |
| 6                      | 1           | 47.95                                       | 49.40                                       |
| 7                      | 2           | 44.88                                       | 46.18                                       |
| 8                      | 0           | ---   | ---   |
| 9                      | 1           | 44.74                                       | 47.20                                       |
| 10                     | 1           | 48.92                                       | 50.68                                       |
| 11                     | 5           | 46.59                                       | 48.34                                       |
| ALL MANY AXLE VEHICLES | 23          | 45.81                                       | 47.11                                       |

\*-AS DEFINED IN TABLE 1  
(\*\*)-AVERAGE OF CATEGORIES 2 THROUGH 5

Vehicle Position Effects

The headways of all vehicles as a function of vehicle position are shown in Table 7. The values for position 1 are lead vehicle clearing times, defined as the time between onset of green and the vehicle's last axle reaching the first tape. As all cycles did not have the same number of vehicles passing through the intersection, a decrease in sample size occurs with increasing vehicle position. For the right lane, the headways in positions two and three are larger than for any other positions, in keeping with published results that the first three vehicles use more green time than others (see, e.g., p. 352 of Ref. 1). In the left lane the second and third position headways are not different from the others. The headways for positions 20 and above are shorter than average because such data arose only for cycles of above average throughput, which were therefore associated with below average headways.

TABLE 7. AVERAGE HEADWAY (SECONDS) VERSUS QUEUE POSITION

| VEHICLE POSITION | RIGHT LANE  |                 |                    | LEFT LANE   |                 |                    |
|------------------|-------------|-----------------|--------------------|-------------|-----------------|--------------------|
|                  | SAMPLE SIZE | AVERAGE HEADWAY | STANDARD DEVIATION | SAMPLE SIZE | AVERAGE HEADWAY | STANDARD DEVIATION |
| ( 1)             | (408)       | (6.78)*         | (1.48)             | (381)       | (6.17)*         | (1.03)             |
| 2                | 408         | 2.29            | 0.91               | 381         | 1.95            | 0.70               |
| 3                | 408         | 2.26            | 1.14               | 381         | 1.98            | 0.73               |
| 4                | 408         | 2.19            | 1.10               | 381         | 1.96            | 0.62               |
| 5                | 407         | 2.16            | 0.92               | 381         | 1.94            | 0.67               |
| 6                | 404         | 2.15            | 1.02               | 380         | 1.91            | 0.60               |
| 7                | 403         | 2.11            | 0.99               | 380         | 2.07            | 1.52               |
| 8                | 403         | 2.01            | 0.81               | 378         | 2.07            | 1.58               |
| 9                | 403         | 2.04            | 0.88               | 377         | 1.97            | 0.97               |
| 10               | 402         | 2.19            | 1.11               | 375         | 2.07            | 1.27               |
| 11               | 401         | 2.11            | 1.05               | 374         | 2.09            | 1.23               |
| 12               | 398         | 2.21            | 1.19               | 373         | 2.19            | 1.36               |
| 13               | 393         | 2.18            | 1.24               | 366         | 2.14            | 1.29               |
| 14               | 387         | 2.13            | 1.06               | 362         | 2.17            | 1.28               |
| 15               | 379         | 2.16            | 1.01               | 354         | 2.06            | 0.91               |
| 16               | 362         | 2.11            | 0.92               | 350         | 2.13            | 1.12               |
| 17               | 338         | 2.18            | 1.12               | 338         | 2.07            | 1.06               |
| 18               | 305         | 2.07            | 0.86               | 323         | 2.09            | 0.98               |
| 19               | 246         | 2.10            | 1.02               | 292         | 2.02            | 0.81               |
| 20               | 185         | 1.85            | 0.81               | 233         | 1.87            | 0.65               |
| 21               | 111         | 1.92            | 0.85               | 169         | 1.95            | 0.84               |
| 22               | 57          | 1.84            | 0.73               | 99          | 1.71            | 0.58               |
| 23               | 18          | 1.69            | 0.59               | 47          | 1.73            | 0.55               |
| 24               | 4           | 1.43            | 0.47               | 18          | 1.66            | 0.64               |
| 25               | 0           | --              | --                 | 6           | 1.38            | 0.15               |
| 26               | 0           | --              | --                 | 1           | 1.80            | --                 |
| ALL EXCEPT FIRST | 7230        | 2.13            | 1.02               | 7119        | 2.03            | 1.06               |

\*THE ENTRY FOR THE FIRST VEHICLE IS CLEARING TIME

Ancker, Gafarian and Grey [7] found successive headways to be independent random variables. We have applied a similar, but less extensive, analysis to our data. An examination of the correlation coefficients  $r_{i,i+1}$  between the  $i^{\text{th}}$  and  $i+1^{\text{th}}$  headway for all positions,  $i$ , led to the conclusion that headways in the present study were essentially independent random variables, in accord with the previously mentioned [7] finding.

The vehicle headways in Table 7 may be converted to passenger car values by dividing the right lane headways by 2.13/2.01 and the left lane headways by 2.03/2.01.

The average speed and acceleration at the trap for vehicles in given positions (including position 1 - the queue leader) are shown versus vehicle position in Figure 7. Note that for high platoon positions, the acceleration is actually negative. This is likely a manifestation of a speed correction effect that has been observed in starting platoons of buses [13] and cars [14] in test track experiments.

#### DISCUSSION

The present data set offers evidence that drivers of smaller sized cars adopt smaller inter-vehicular spacings than the drivers of standard-sized cars. A dependence of spacing on amount of visible roadway [4,5] might not necessarily lead to car-size effects in the present study. Although, in general, forward obscuration increases with vehicle size for typical passenger cars, there are many counter-examples in other vehicles. Sport cars with long hoods and therefore long forward obscuration are in category 2; vans with very short forward obscuration are in the larger size categories. Smaller vehicles typically have lower power to weight ratios, so that larger gaps could arise from an inability to match lead-car accelerations. Such effects could also bear on an earlier finding that different size passenger car queue leaders did not affect throughput. These effects could also help explain why the

---



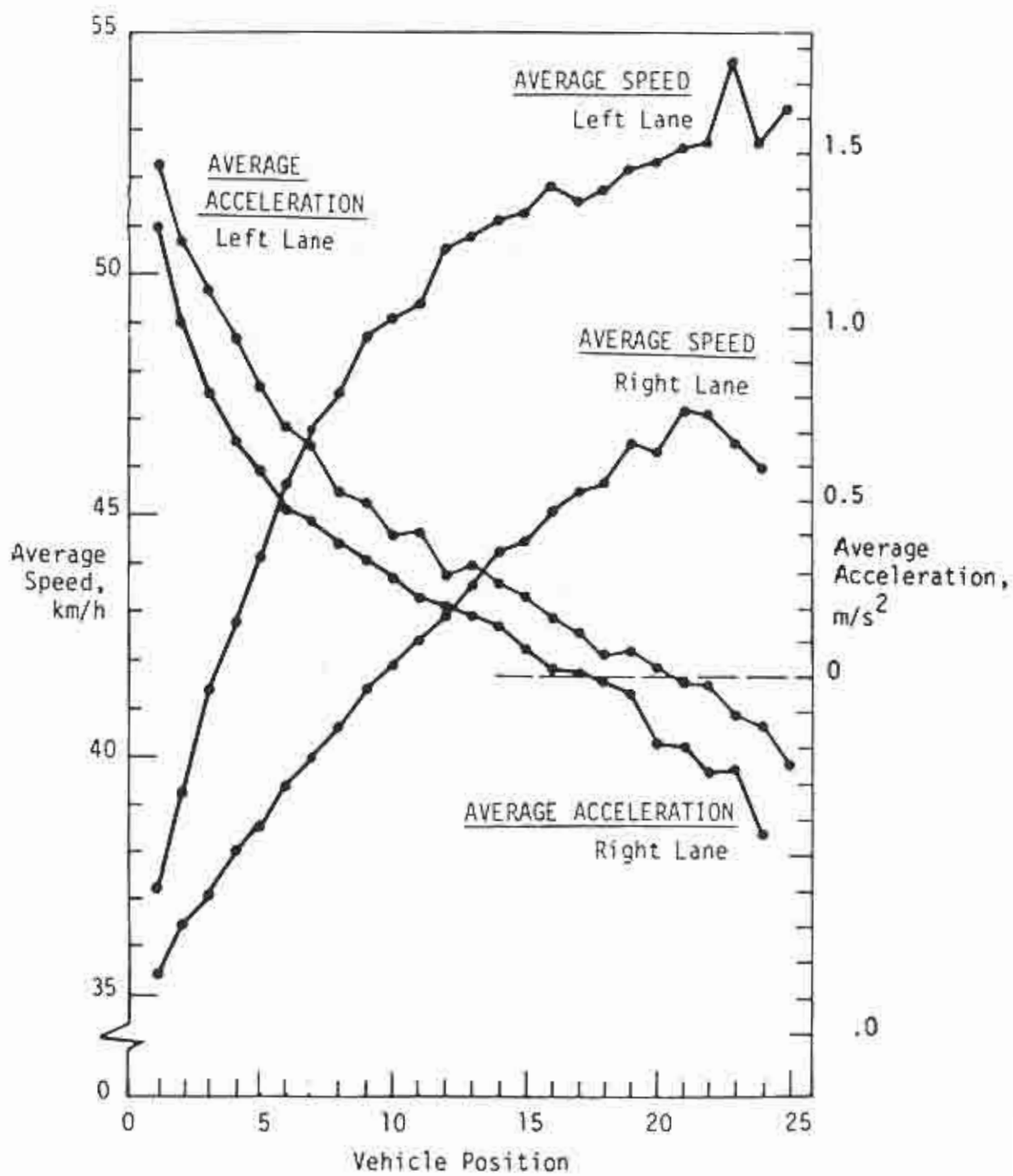

Figure 7. Average speed and acceleration versus position of vehicle in queue.

clear-cut car-size effects observed at a clearing line [3] were not observed in the present study.

Intersection saturation flow was found to be a linear function of the time required for the lead vehicle to travel a typical distance (15 m) to clear an intersection. One passenger car equivalent (pce) of saturation flow was lost for each 1.92 s of additional time the queue leader required to travel this distance. This result may be used to infer effects of low performance vehicles on urban traffic.

Recent experiments [15] have shown that in order to accelerate vehicles from rest to cruising speeds using the least amount of fuel drivers should use lower levels of acceleration than the average values currently encountered in traffic [15]. However, it is an extremely complicated problem to relate how individuals attempting to conserve their personal consumption of fuel by using lower levels of starting acceleration would affect the overall urban traffic system [16,17]. Any reduction in intersection throughput resulting from drivers choosing very low accelerations in an urban traffic system working at near capacity could have highly non-linear deleterious effects on delay, and therefore, on fuel consumption [18, 19]. Indeed, if all drivers in an urban traffic system try to minimize their individual fuel consumption, a possible result might be to increase their collective fuel consumption [15, 16].

Substantial reductions in saturation flow were attributed to large vehicles, particularly those with more than three axles, which in this discussion will, for convenience, be called "heavy trucks". A heavy truck in a non-leader position was equivalent to 2.63 passenger car equivalents (pce). On the other hand, a heavy truck in a queue leader position was equivalent to 4.05 pce. Compounding this adverse effect on saturation flow of the leader was the finding that heavy trucks were over-represented in the more deleterious leader position. Our data indicated that a random heavy truck in the traffic stream was almost twice as likely to become a queue leader

---

## Intersection Saturation Flow

as was a random passenger car. Indeed, were it not that the trucks were also more likely to enter the intersection during the red phase the number of trucks becoming queue leaders would have been even greater.

These findings have important implications for automatic control schemes aimed at minimizing fuel consumption. Already computer-controlled schemes in Tokyo [20], Glasgow [21] and Toronto [22] have been described in the literature. In the future, it would seem feasible to identify vehicles in greater detail, perhaps using a trap similar in principle to the one in the present observations. One algorithm would be to change the signal light from green to red when a large gap occurred. However, these results show that such a policy would further increase (beyond its already high value) the probability that heavy trucks would be queue leaders. Stopping a heavy truck as a queue leader has a doubly detrimental effect on system fuel consumption. First, the heavy vehicle will use substantially more fuel [12] idling and regaining its original speed than a passenger car. Secondly, the heavy truck in a queue leader position has a more adverse affect on cycle saturation flow. Hence, control algorithms to minimize system fuel consumption should operate so as to reduce the likelihood of heavy trucks becoming queue leaders.

### ACKNOWLEDGMENTS

George Gorday and Stanislaw Koziel are acknowledged here for their valuable technical support. James Stephens is thanked for his skillful work in performing some of the data analysis. Helpful referee comments are incorporated in this version. Finally, grateful acknowledgement is extended for the support and encouragement of Robert Herman, with whom several fruitful discussions have occurred.

---

REFERENCES

1. L. J. Pignataro, Traffic Engineering - Theory and Practice. Englewood Cliffs, New Jersey: Prentice-Hall, Inc., 1973 .
  2. R. Herman, T. Lam and R. Rothery, "An Experiment on Car Size Effects in Traffic," Traffic Engineering and Control, 15, 90-93, 99, June 1973.
  3. Steuart, G. N. and Shin, B., "Effect of Small Cars on the Capacity of Signalized Urban Intersections," Transportation Science, 12, 250-263, 1978.
  4. J. Almond, "Effect of Forward Visibility, Power/Weight Ratio and Type of Transmission of Cars on the Capacity of Traffic Signals," RRL Report LR 60, Road Research Laboratory, Crowthorne, England, 1967.
  5. L. Evans and Richard Rothery, "The Influence of Forward Vision and Target Size on Apparent Inter-Vehicular Spacing," Transportation Science, 10(1), 85-101, February 1976.
  6. Briggs, T. "Time Headways on Crossing the Stop-Line after Queuing At Traffic Lights," Traffic Engineering and Control, May 1977, 264-265.
  7. C. J. Ancker, Jr., A. V. Gafarian and R. K. Gray, "The Oversaturated Signalized Intersection -- Some Statistics," Transportation Science, 2(4), 340-361.
  8. L. C. Edie, R. S. Foote, R. Herman and R. Rothery, "Analysis of Single Lane Traffic Flow," Traffic Engineering, January 1963.
-

## Intersection Saturation Flow

9. "Heavy Duty Vehicle Driving Pattern and Use Survey: Part II - Los Angeles Basin Final Report," U.S. Environmental Protection Agency, Ann Arbor, Michigan, EPT-460/3-75-005, February 1974.
  10. A. Dockerty, "Accelerations of Queue Leaders from Stop Lines," Traffic Engineering and Control, 8(3), 150-155, July 1966.
  11. D. C. Gazis, R. Herman and A. A. Maradudin, "The Problem of the Amber Light in Traffic Flow," Operations Research, 8, 112-232, 1960
  12. L. Evans and R. Rothery, "Comments on Effects of Vehicle Type and Age on Driver Behavior at Signalized Intersections," Ergonomics, 19(5), 559-570, 1976.
  13. R. Herman, T. N. Lam and R. Rothery, "Further Studies on Single Lane Bus Flow: Transient Characteristics," Transportation Science, 4(2), 187-216, 1970.
  14. R. Herman, T. N. Lam and R. Rothery, "The Starting Characteristics of Automobile Platoons," Proceedings of the Fifth International Symposium on the Theory of Traffic Flow and Transportation, June 1971.
  15. L. Evans and G. M. Takasaki, "Fuel Used to Accelerate Vehicles from Rest to Cruising Speeds," Society of Automotive Engineers, SAE paper No. 810781, June 1981.
  16. M.-F. Chang, L. Evans, R. Herman and P. Wasielewski, "Gasoline Consumption in Urban Traffic," Transportation Research Record 599, Transportation Research Board, Washington, D.C., 25-30, 1976.
-

Evans and Rothery

L. Evans, "Driver Behavior Effects on Fuel Consumption in Urban Driving," *Human Factors*, 21(4), 389-398, 1979.

L. Evans and R. Herman, "A Simplified Approach to Calculations of Fuel Consumption in Urban Traffic Systems," *Traffic Engineering and Control*, 17(8,9), 352-354, August/September 1976.

L. Evans, "How Does Traffic Speed Affect Urban Fuel Consumption?", *ITE Journal*, Institute of Transportation Engineers, June 1979 and September 1979.

20. H. Inose, "Road-Traffic Control with the Particular Reference to Tokyo Traffic Control and Surveillance System," *Proceedings of the I.E.E.E.*, 64(7), 1028-1039, July 1976.

21. J. R. Pierce and K. Wood, "Bus TRANSYT - A User's Guide" TRRL Supplementary Report 266, Transport and Road Research Laboratory, Crowthorne, England, 1977 (also see references cited in this report).

22. L. Rach, J. K. Lam, D. C. Kaufman and D. B. Richardson, "Evaluation of off-line Traffic-Signal Optimization Techniques," *Transportation Research Record* 538, 48-58, 1975.

P. J. Claffey, "Running Costs of Motor Vehicles as Affected by Road Design and Traffic," NCHRP, Report III, 1971.

---